THE ORION 100c

RELIABLE WELDING TECHNOLOGY



MADE IN THE USA

ORION 100c

THE RELIABLE WELDING TECHNOLOGY YOU NEED!



BENEFIT: **Save Time!**

The Orion 100c is the reliable welding tool that every metalsmith should have. Save time doing simple and complicated work such as seam joints, filling porosity, adding metal, attaching different size pieces, or any other application you may encounter. Increase efficiency with this easy to use system!



TECHNOLOGY: **How Does it Work?**

Electrical Energy – Plasma Discharge:

Pulse Arc welding uses electrical energy to create a plasma discharge. The high temperature plasma in turn melts metal in a small spot. This process takes place in milliseconds. The process is clean, and very controllable – perfect for intricate and minute welding applications on precious and non precious metals! Filler metal can also be added to build up joints and create strong and reliable weld "beads", or weld seams.

Two in One Combo:

The Orion is a pulse-arc welder and a capacitive discharge resistance welder in one. This combination of abilities allows for infinite creative possibilities. In its Tack Mode the Orion can be used to temporarily position parts before welding or soldering. In its Pulse Arc Mode, the Orion can be used to perform permanent welds, add metal, and do a variety of other amazing and time saving applications.

**MADE
IN THE USA**

KEY FEATURES: **Why Buy An Orion 100c?**

Precision and Power:

Select power in 0.5 Ws increments up to 100 Ws —That's over 100 available power settings! Weld spot sizes range from microns all the way up to 2.5mm. Whatever it is you weld, Orion has the power to get the job done.

Weld Ignition Options:

This technology prolongs the life of the electrode by lifting the electrode prior to releasing the weld. This safeguards the electrode from misfires and sticking to the workpiece. In turn, you spend more time welding and less time sharpening an electrode.

Full Touch Screen:

The Orion touch screen gives you complete control of your welder with an easy to use interface. No knobs or dials, just one touch access to everything you need. This makes the 100c intuitive to use and easily upgradeable for future features as they are released in free software updates.

Superior Customer Service:

Before, during, and after the sale, we want to be your resource for years to come. We guarantee that every interaction with our company will be courteous and friendly in answering your questions or helping in any way we can.

Highest Quality Standards:

When you purchase an Orion 100c, take confidence in knowing that it was designed, produced, and assembled to the highest quality standards in the industry—in other words, it's the best you can buy.

MADE 
IN THE

APPLICATIONS: What Can It Do?

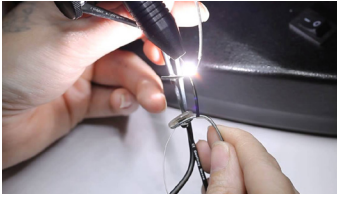

- Hollow Pieces
- Seam Welding
- Electronic Components
- Add Metal
- Fill Porosity
- Small Wires
- Attach Separate Pieces



- Weld Dissimilar Metals
- Posts
- Small Parts
- Dental Lab Repairs
- Jewelry Repairs
- Eyeglass Repairs
- Mold and Die Repair

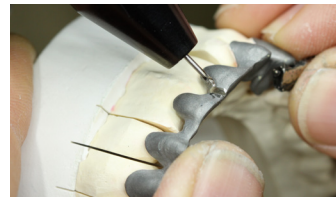
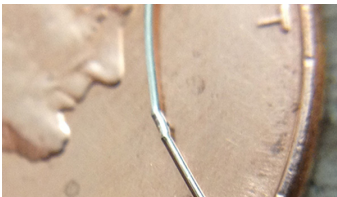

THE ORION INTERFACE: Welding Made Easy

The Basic Screen:

Whether you are an expert at pulse-arc welding or doing it for the first time, we have developed a simple and intuitive, step by step system, for you to follow when welding.

Step 1:

Choose the metal you are welding.

Step 2:

Select the type of application you are performing.

Step 3:

Choose your power. Not sure what power to choose? Look to the spot size indicator above the power bar for a reference *From the Basic Screen the 100c will change the welding time automatically as you move the power up or down.



Step 4:

Select the agitation and ignition type.

Step 5:

Choose between Touch Detect or Foot Pedal.

MADE IN THE USA

TECH SPECS

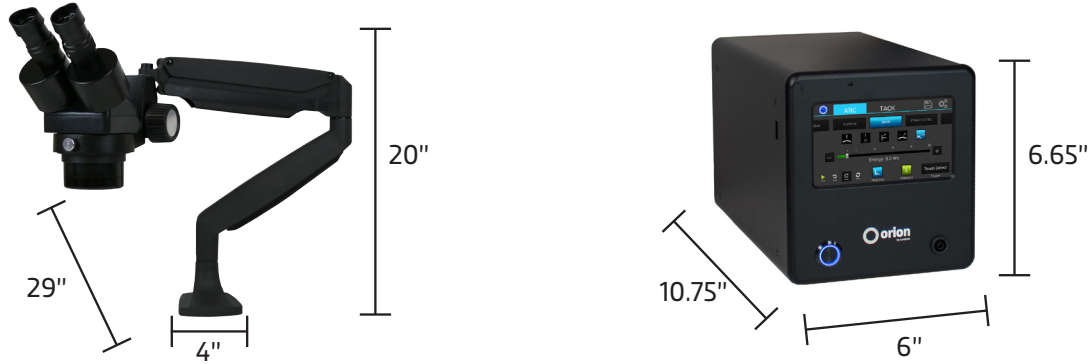

Footprint (L x W x H) 1-29" x 4" x 1-20"

Orion 100c Pulse Arc and Resistance Welder	
Weld Modes	Pulse-Arc & Resistance
Pre-Programmed Metal Settings	11
Customizable Save Settings	30
Languages	Multiple (Ask rep if we have your language)
Display	5" Capacitive Touch Screen
Pulse Arc Weld Energy (Ws)	3-100 Ws
Tack Weld Energy (Ws)	3-100 Ws
Switching Power Supply	110/240VAC (Auto Detected)
Weld Spot Diameter	0.75 - 2.5mm
Footprint (L x W x H)	10.75" x 6" x 6.65" (27.3 x 15.2 x 16.9cm)
Weight	11.8 lbs (5.35 kg)
Stereo Microscope Magnification	5x



CE TESTED AND CERTIFIED

Welder tested for electrostatic discharge immunity up to 2kV for CE compliance

2 YEAR WARRANTY

MADE IN THE USA