



## IMPORTANT!

Please read before unpacking your mill.

You have just received the highest quality rolling mill. With the correct care, it will last many years and possibly a lifetime

Please read and understand pages 1, 2 and 3 before taking your mill out of the box. If you are uncertain about any part of these instructions, or you have any concerns, please contact us.

If you have any further queries or questions relating to your Rolling Mill, please do not hesitate to contact us:

✉ [support@durston.com](mailto:support@durston.com)

☎ +44 (0) 1494 535388 / +44 (0) 1494 526777

🌐 [www.durston.com](http://www.durston.com)

# Instructions/Maintenance for Hand Operated Rolling Mills

## Unpacking and preparing your new mill for use

### Lifting

Please unpack the rolling mill very carefully. For all mills, have at least two people lifting and moving the mill into its final place. Never lift from the hand wheel, always lift from the base of the mill. For the D2 130 and D4 158, please lay these down and lift from both sides and have four people to lift and move the mill. Make sure that you lift the cast base at the bottom and steel plate at the top of the machine. Do not lift using the hand wheels. Make everyone aware of the weight before lifting so everyone understands the weight they are lifting. The approximate weights of the machines are as follows: Mini Mills: 16kg, DRM100: 32kg, Agile110: 30kg, DRM130 & DRM150: 50kg, Agile130: 43kg, Agile165: 50kg, D2130: 75kg and D\$158: 85kg.

### Securing

Bolt machines securely to a Durston stand or strong secure bench. Ensure that the stand or bench is bolted down to the floor.

### Fitting Turning Lever

You now need to fit the lever. Slide the lever as shown in the picture (you may need to tap it) and do up the 10mm grub screw with the allen key provided. Do not over tighten, you may damage the shaft. Every month, check that this screw is tight.



### Removing Rust Preventative

You will need to remove the rust preventative on the rolls. Close the rolls and then open the rolls up by one turn of the hand wheel (D). Sparingly apply white spirit onto a clean cloth and hold the cloth into the gap of the rolls and then roll backwards. Do not use a liquid that is stronger than white spirit or a lacquer thinner. It will take a little longer on the grooves and they will need to be cleaned one at a time.

## Maintenance

### Mini Mill 50, 70, 80 and 100

- The bearings are self-lubricating and need no maintenance.
- The drive gears at the left-hand side (behind guard A) should be greased every 12 months. Remove the circlips and extension rollers and then the two screws for the cover for access to the 2 gears (see page 3 for detailed pictures). Use standard gear grease.
- Oil the four end faces of the rolls weekly (F). See enlarged view of rolls below.

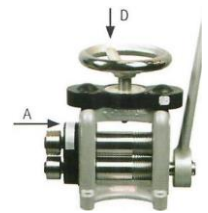

### DRM 100, 130 and 150, Agile 110, 130 and 165

- The bearings are self-lubricating and need no maintenance.
- The drive gears at the left-hand side (behind guard A) should be greased every 12 months. Remove the circlips and extension rollers and then the two screws for the cover for access to the 2 gears (see page 3 for detailed pictures). Use standard gear grease.
- The gear box at the right-hand side (B) should be greased every 12 months. Remove the turning lever (C) – to do this, slacken the 10mm set screw (5mm allen key), the handle should then slide off. If not, gently tap it. Now remove the four 5mm cap screws (4mm allen key), the lid for the gear box should now come off. You may need to gently tap this too. Use standard gear grease. (Not applicable for economy models)
- Oil the 4 end faces of the rolls weekly (F). See enlarged view of rolls below.

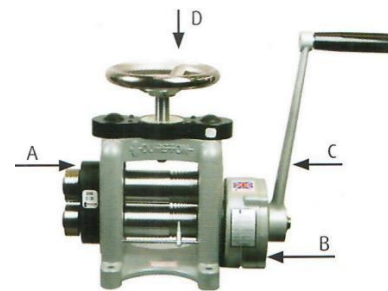

### D2 130 and D4 158

- The bearings are self-lubricating and need no maintenance.
- The drive gears at the left-hand side (behind guard A) should be greased every 12 months. Remove the circlips and extension rollers and then the two screws for the cover for access to the 2 gears (see page 3 for detailed pictures). Use standard gear grease.
- The gear box at the right-hand side (B) should be greased every 12 months. Remove the lever, slacken the 10mm set screw first (5mm allen key). The lever should slide off, if not, gently tap it. Now unscrew the 4 screws holding on the black guard. The cover can now be removed. Use standard gear grease.
- Oil the 8 end faces of the rolls weekly (F). See enlarged view of rolls below.

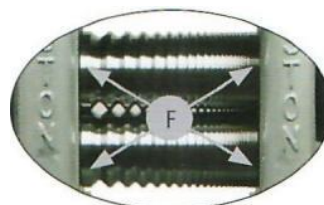
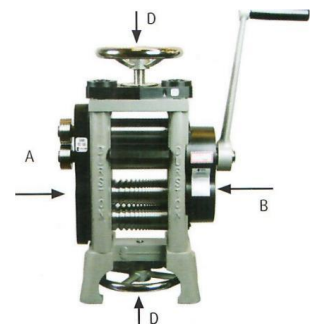

## D4 158 Additional Instructions

- The D4 158 has a second lever which is used for doubling the turning speed of the rolls. This second lever is useful when you are rolling out the smaller jobs where not so much effort is required, making the rolling quicker. For larger jobs, the lower lever, which is located on the wire roll, is the best to use as it gives you the maximum reduction on the gearbox.
- To change the standard lever (lower lever on the wire roll) to the second lever, remove the circlip on the wire roll (right-hand side) and the first lever will slide off. Now insert the second lever into the cover on the lower sheet roll. The two hardened dowels will locate into the gear. Then tighten up the two 10mm bolts (17mm spanner).
- When turning with the standard lever, turn the lever anti-clockwise. When using the second lever, turn clockwise.

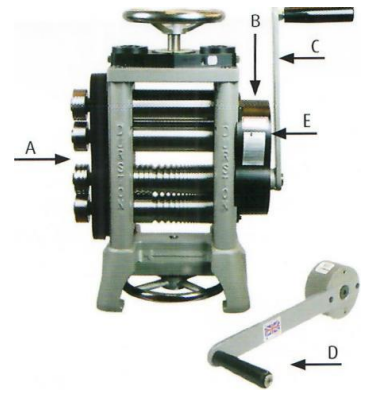

## Procedure for Rolling

### Sheet Rolling

*Please note that the following is only a guide.*

1. Anneal the piece of sheet or ingot, pickle it, and rinse it with clean water. Now dry it.
2. Feed the dry metal into the mill, applying snug (but not overpowering) pressure on rollers.
3. After rolling the metal through the mill, flip the piece end to end before you roll it through again. You will get a more even roll.
4. Before passing metal through the rollers, lower the rollers until you have a snug fit (as in step 2).
5. If the metal becomes hard to roll, it must be annealed again. Then roll the piece through the rollers, repeating as necessary until the desired thickness is achieved.
6. When rolling silver sheet, it may be necessary to anneal the sheet after rolling it from 3mm to 1mm thickness. For 14ct gold, the annealing may be necessary after rolling from 3mm to 2mm.

### Wire Rolling

*Please note that the following is only a guide.*

Reduce the wire by rolling 2 or 3 times in each groove rotating the wire 90 degrees on each pass. Rolls should be nearly closed for the last pass before moving to the next groove. Depending on the material, passes of up to 30% can be achieved. The material should be annealed as often as necessary to avoid excessive force when rolling. Indications of excess hardness are frayed edges, wrinkling of surface, surface cracking or excessive force needed to turn the rolls.

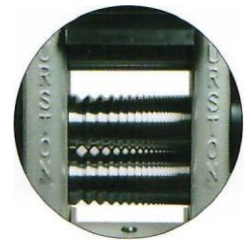

### Trouble Shooting

PROBLEM	CAUSE	SOLUTION
The edges of the metal are cracking.	When the metal was poured, the ingot is not uniform in shape or the metal was rolled too much without annealing	Remove the part of the metal with the crack (by sawing), anneal, and then hammer out the metal around the missing section until the edges are even. Anneal again and then re-re-roll.
The surface of the metal is flaking and/or cracking.	<ol style="list-style-type: none"> <li>1. When the metal was poured, the ingot mould was cold.</li> <li>2. There may be too much old metal in the ingot.</li> <li>3. The ingot was annealed too much.</li> <li>4. There may be foreign metal in the ingot.</li> </ol>	Melt the ingot and reform in the ingot mould. Roll it out again. If the problem persists, it may be necessary to refine the metal before you use it again.
When wire is rolled out, it is wavy or bent.	<ol style="list-style-type: none"> <li>1. There was not enough tension applied to the free end of the wire.</li> <li>2. Too much pressure is being exerted by the rollers.</li> </ol>	<ol style="list-style-type: none"> <li>1. Hold the free end of the wire tight with one hand.</li> <li>2. Remove sheet, anneal it, planish the distorted sections and re-roll. Apply less pressure to the rolls.</li> </ol>
When rolling sheet, it buckles.	Sheet was pushed through rollers after flipping end to end without annealing.	Remove sheet, anneal and re-roll.

# Rolling Mill Safety, Care and Tips

## Safety

1. Always bolt down your rolling mill to a secure bench or secure stand for stability and safety. Also ensure that the bench or stand is securely fixed to the floor.
2. Ensure guards are in place at all time. The guards are the black plastic covers, covering the gears.
3. Do not lift the mill by the hand wheel, only lift from the base. Always make sure at least 2 people carry the mill.

## Care

1. When the rolling mill is not in use, apply a thin coating of ruse preventative liquid. Using a clean and dry paint brush (approximately 12mm wide) apply the rust preventative across the rolls. Turn the rolls as you do this. Make sure the rolls are nearly closed. This will spread the liquid evenly over the surface. It is very important that your rolls are always protected, especially in moist/wet/hot conditions or where temperatures are changing. Once your rolls are marked/rusty/corroded they will be like this until you have them removed and reground. (However, please note that it is almost impossible that you will end up with perfect rolls. Over time and use they will get slightly marked but will still work perfectly well). When using your mill again remove all rust preventative and ensure your rolls are clean and dry before you start to roll material. See "removing rust preventative" at the beginning of this manual.
2. It is also recommended that you cover your mill when not in use. This is to prevent the rust preventative from collecting dust and dirt.
3. Keep the rolls clean. Do not touch the rolls. Oils and acids from your body can damage the rolls, leaving behind small marks and eventually rust.
4. Make sure all material is dry before rolling.
5. Do not use your mill with the rolls completely closed.
6. Do not roll ferrous metals such as iron or steel through the mill.
7. Always release pressure on the rollers after you have completed your job.

## Adjusting Parallel



Remove black circlip (ring) on shaft



Lift up handwheel (with gear and shaft attached)



Move one of the gears, 1 tooth and replace handwheel assembly. Now roll material. Repeat this step (if necessary) until material comes out straight.

## Greasing Drive Gears



Remove black circlip (ring)



Remove 2 screws and cover



You can now grease the gears

## Greasing Gearbox

Screws for adjusting roll position. Do not adjust



Undo screw in turning handle and slide off



Remove 4 screws and remove circlip (ring)

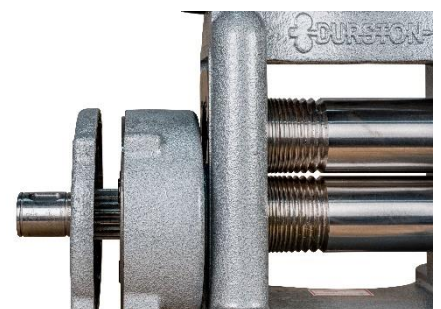

Remove top plate of gearbox to expose the gears for greasing

# Rolling Mill Printing

The following ideas and techniques of jewellery manufacturing are reproduced by kind permission of Sandra Nobel Goss

(These advanced techniques assume that you have basic jewellery and metalworking skills. We offer these technical papers, originally presented as workshops, in a spirit of sharing information. We assume no liability for safety and health issues – those are your responsibility.)

## The Rolling Mill

The rolling mill is a machine designed to produce thinner gauges of sheet metal and wire. Most studio jewellers use a hand cranked mill (although automated mills are used as well). Each mill consists of two smooth, highly polished hardened steel rolls, mounted in the housing parallel to each other. The rolling mill is used for reducing the thickness of sheet metal. The rolls for wire are cut with 'V' shaped grooves arranged in decreasing sizes, allowing for gradual reduction of wire diameter and producing a square cross section of wire. Most studio jewellers choose a 'combination' mill – half of the roll is smooth (for sheet metal) and half is grooved (for wire). This limits the width of the metal to be rolled (averaging about 50-60mm).

## Introduction to Printing

Metal which is passed through the rolling mill under pressure with another material will become embossed with a pattern exactly the same as the material being used. Any small particle trapped between the metal and roll will 'imprint' on the metal. If you are attempting to roll a perfectly smooth piece of metal, this is not desirable. But the principle can be put to use to create embossed patterns and designs on metal.

The best way to imprint metal is to create a 'metal sandwich' with two pieces of metal (to be impressed) on the outside (the 'bread' in the 'sandwich') and the material being used as pattern between them (the 'filling').

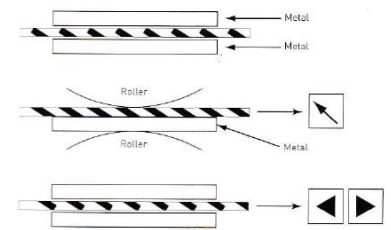

## One-Sided vs. Two-Sided Imprinting

If you wish to imprint on one sheet of metal only, roll the metal together with the imprinting material, using the roll as the other side of the 'sandwich'. This technique is preferable when using expensive materials (gold and sterling) but has its drawbacks, as there is more possibility of damaging the rolling mills if materials that are too hard are used for imprinting. It is best to make a 'metal sandwich' whenever possible – it produces two pieces of usable, imprinted metal with mirror image imprints (especially useful for earrings, being symmetrical, but reversed).

### ROLL PRINTING PROCESS

1. Metal to be imprinted must be annealed, dry and clean. Depending on the use of the metal after being imprinted, you may wish an emery finish or Tripoli rouge polish. Usually the metal that is the pattern (the 'filling' in the sandwich) should not be annealed – if it is hard metal you will get a better imprint and may be reusable.
2. The pattern imprinted will be a reverse of the design (important to remember if using letters and numbers in the design).
3. An object placed between the two pieces of metal will create a recess in the metal (intaglio; a mechanical 'etching' effect). As the 'metal sandwich' passes between the rolls and is compressed, the imprinting material is pushed into the metal. Be careful not to roll the imprint so that the metal becomes too thin.
4. Make one pass only! Carefully adjust the gap by attempting to roll the first ½ inch (1cm) or so. Trial and error and experience, along with written notes, are all part of this process. Once the correct gap is calculated, roll the whole piece in one continuous roll. Try not to stop part way through the pass.
5. To emboss: use a plate with negative spaces so that when rolled the metal plates push into the recessed shapes on the pattern.

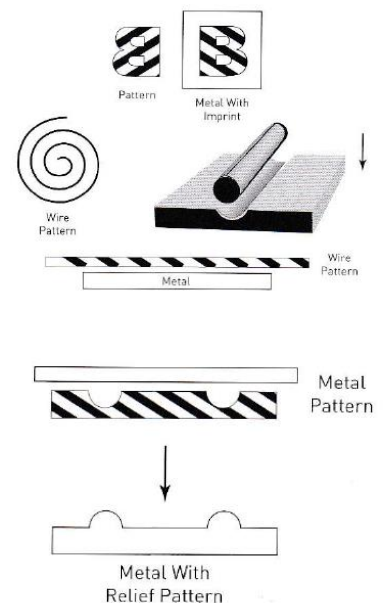

## Methods of Roller Printing

### Objects and Materials that can be used to make Patterns

Objects that are too thick or three dimensional may not be appropriate (the metal is usually not thick enough to encompass the object and give a good imprint). Hard metal objects (steel) should only be used in the two-sided ('metal sandwich') method, as they may damage the steel rolls. The rolls should be cleaned thoroughly after using gritty materials like sandpaper. Thin metal should only be used with thin objects – thick imprinting patterns will make the metal too thin and weak. Some materials and objects that can be used (there are many more – experiment):

Paper	Metal	Lace	Washers	Leaves	Sandpaper
Fabric	Screen	Wire	Plastics	Doilies	Netting
Thread	Feathers	Masking Tape	Sequins	Thin Keys	Chain

### Wire Section of Rolling Mill:

Rolling sheet metal through the grooved wire section of the rolls produces a corrugated effect. If the metal is passed through again at a different angle a cross-hatched pattern is achieved. Turned 90 degrees produces a chequered effect.

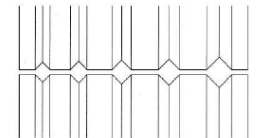

### Masking Tape:

Masking tape will provide a textured pattern recessed into the surface of the metal. Lay tape out on a sheet of glass and cut desired shapes with a blade. Because the shape adheres to the metal, there is little movement of the design during the rolling process. Multiple layers can be used to give variety of depths.

### Paper:

Paper provides a wonderful, sharply details imprint on well annealed metal. The metal picks up a matte texture from the paper. Where shapes have been cut out, metal will contact metal leaving a shiny pattern in contrast to the paper texture. Shapes can be cut out with a knife, with fine nail scissors or by folding the paper and cutting the folds (good for an overall repeat pattern). Multiple layers of paper can be used – giving both embossed and recessed designs. A paper pattern can only be used one time. If you wish to repeat a pattern you can photocopy the design and cut out each time. Experiment with different sorts of paper from regular bond, to tissue, to heavy watercolour papers.

### Metal Patterns and Pierced Designs:

Metal shapes: different shapes can be cut out of metal and used to imprint. Cutting into a sheet of metal can produce intricate designs which will emboss the finished piece. Drilled holes will give small raised circles; saw cuts will give fine raised lines. Since saw piercing goes right through the metal pattern, a two-sided imprint will work. Wire can be used effectively to create linear intaglio patterns.



Treasure Pin: Brass (roller printed using pierced metal), Sterling Silver (fused). 5.5cm  
© Sandra Noble Glass

### Hammer and Punch Textures:

Designs can be made into a sheet of unannealed metal using punches, coarse files and hammers. This piece of patterned metal can be used for a one-sided imprint (making one copy only). Since the pattern is recessed into the pattern plate, the resulting pattern on the finished piece of metal will be embossed (raised above the surface). An old hammer can be engraved or filed with textures. When it is hammered onto metal it leaves an embossed pattern. These can be used to give added texture to a pattern.

### Rolled Plate as Pattern:

Designs can be imprinted onto a metal sheet which in turn can be used as a pattern. If the original design is recessed, it will produce an embossed pattern which has an increasing quality as it is one step removed from the original process.

### Aluminium Plate:

Aluminium plates can be engraved easily with gravers or dental burrs on the flexible shaft. They are good for only one (at the most two) passes. The thicker the aluminium plate the deeper the cuts and the deeper the embossing.

### Etched Plate Pattern:

Brass, bronze, copper and mild steel can be acid etched to create patterns for roller printing. Steel is useful for a plate you may wish to reuse many times. Thick brass and bronze will produce plates that can be reused.

## To Etch Steel:

Use one part nitric acid to three parts water or two parts hydrochloric acid (muriatic) to one part water. **ALWAYS ADD ACID TO WATER NEVER THE OPPOSITE! If you are not familiar with acids and their dangers, do not try this! Read about etching in a printmaking book for more details before you proceed.**

Use resists that a printmaker would use (asphaltum etc.). Use in a well-ventilated area and wear rubber gloves and eye protection. Do not inhale the fumes.

## Non-Acid Etching of Copper, Bronze and Brass:

Ferric chloride is a salt which gives a clean etch to copper-based alloys. Follow directions on the bottle. Wear rubber or latex gloves. Tapes such as electrical tape or brown packing tape can be used as resists. The real bonus of this material is that permanent markers used for writing on plastic will resist the etching action which allows you to draw or write (remember to reverse the letters for imprinting) directly on the metal. The ink can be removed with methyl hydrate (alcohol – use fume hood and rubber gloves). The piece to be etched must be suspended upside down (design facing down) below the surface of the ferric chloride. Agitate occasionally for better action. Check the depth of the bite frequently. Clean the metal very well with dish detergent and water. Then clean with toothbrush or brass brush and baking soda to ensure the etching action is neutralised (IMPORTANT). The finished piece can be used to imprint - the etched away sections will emboss.

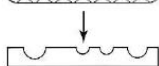
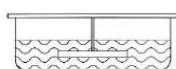
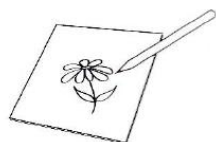

Pattern in Etched Design

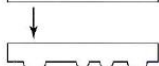
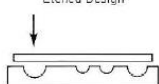

Embossed "Print"

### Increase Embossing Effect:

When roller printing a thin gauge of material, you can enhance the embossing by padding the back of the metal with layers of paper and rolling with more compression.

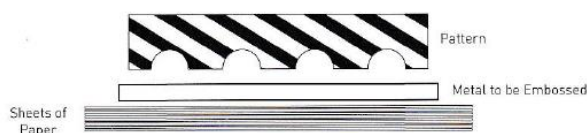

## Methods of Roller Printing

**Solder Inlay:** Designs can be impressed into a sheet of metal and the recesses filled with solder.

**Fold Forming:** Linear patterns can be produced on metal by folding and unfolding the metal. Because the metal has a memory due to work-hardening, the fold remains as a raised line on the surface. Fold metal and pass through the rolling mill to compress the fold. Anneal, unfold the metal and pass through the compress and flatten the top of the fold line. Metal can be folded and unfolded many times, creating parallel or intersecting lines.

**Twisted Wire Lamination:** Twisted and braided wires of different metals, soldered together, can be rolled to create square decorative wires.

**Monkume Gane:** A Japanese technique (means 'woodgrain') of soldering thin sheets of different coloured metal together, rolling them through a rolling mill and relaminating those layers together again. The resulting sheet is then distorted, and the layer revealed by grinding the surface down.

**Other Distortions:** Metal shapes can be purposefully distorted using the rolling mill. Drilled holes can become the perfect ovals (similar but opposite to making an oval from a circle); edges are softened, and straight edges become organic curves. Rolling wire in a paper sandwich gives slightly raised edges to the wire which now has a soft paper texture and is broadened.

**Rolling a Taper:** Wire can be forged into a graceful tapered end which can be used in many ways (spiral or tendrils etc.). The rolling mill provides a shortcut version. Anneal the wire to be tapered. Begin rolling at the first groove and roll as far up as the wire as you wish the taper to extend. Move to the next groove along and roll part way up the wire, leaving part of the first rolled section unchanged. Continue rolling until the wire tapers in a series of steps. Once you have rolled the taper continue refining the taper with a hammer and anvil. Smooth the ridges between the steps with the hammer, turning the wire as you work to round out the squared off edges. If you wish squared taper, do not turn the wire. Once the ridges are smooth out, file, sand and polish the tapered wire. If you wish to shape the taper, anneal and pickle before sanding and polishing.

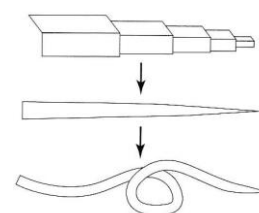



Mini C80 no ext.  
#1000



Mini C80  
#1001



Mini C100  
#1003



DRM C100RE  
#1011



DRM C130RE  
#1021



DRM C150RE  
#1031



Agile C110  
#1019



Agile C130  
#1029



Agile C165  
#1039



Double D2 130  
#1051

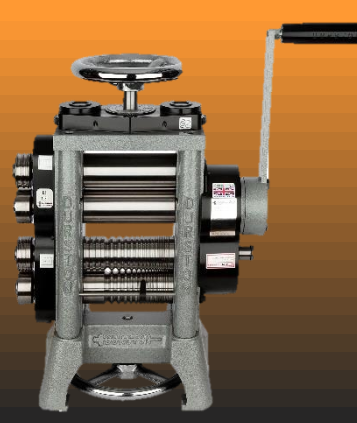

Double D4 150  
#1052