

EXTRA SET OF MANDRELS FOR LARGE RINGS

PART #004-616

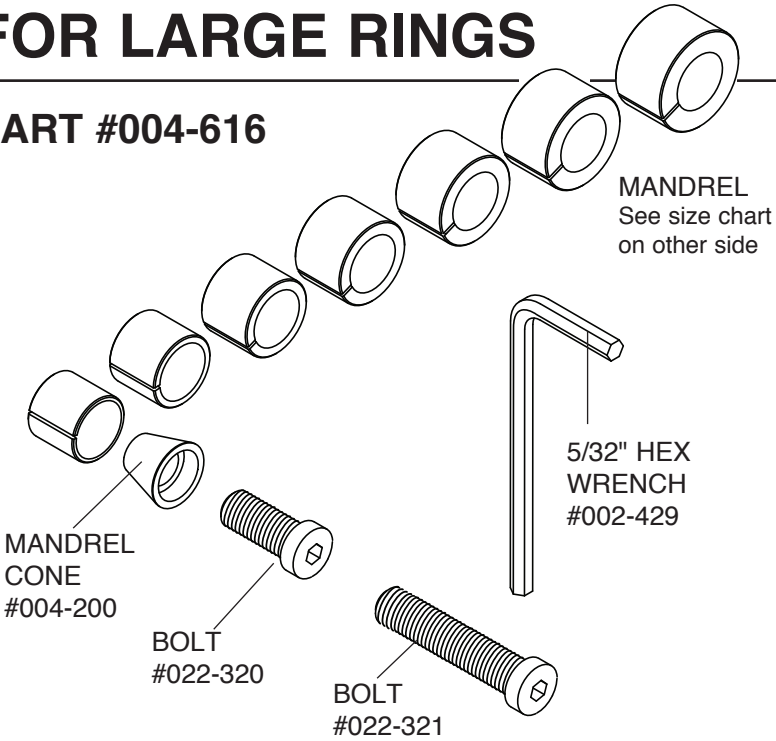

WIDE RING

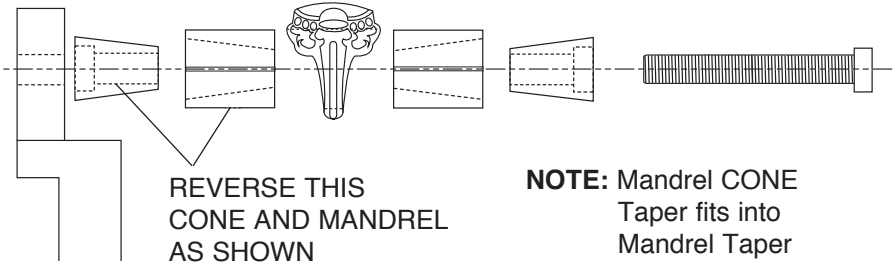

To hold large / wide rings, use TWO of the SAME SIZE mandrels and TWO mandrel cones. Insert the long bolt through the first mandrel cone and place cone into the tapered end of the mandrel selected. Then reverse the second mandrel and place on bolt. Slide the second cone into that mandrel so that the taper angles match. (See illustration above) Position ring on the selected mandrel. Tighten the socket head screw into the Ring Post with the supplied wrench until the ring is snug. **DO NOT OVERTIGHTEN** - Damage may occur to the ring being held.

• HORIZONTAL POSITION • INSIDE RING HOLDER ASSEMBLY FOR VISES

INSTRUCTIONS:

Insert bolt through the mandrel cone and place into the tapered end of the mandrel selected (See illustration).

Position ring around the selected mandrel. Turn the bolt into the ring holder frame with the supplied wrench until the ring is snug.

DO NOT OVERTIGHTEN
Damage may occur to ring.

CORRECT

WRONG

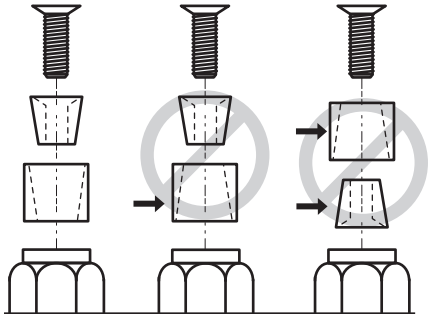

MANDREL

Select the mandrel which is slightly smaller than the inside ring diameter.

#004-170	.575"
#004-171	.625"
#004-172	.675"
#004-173	.725"
#004-174	.775"
#004-216	.825"
#004-217	.875"

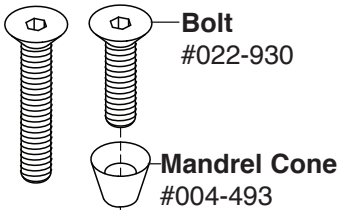

Bolt
#022-930

Mandrel Cone
#004-493

Ring Holder Frame
#004-492

Secure ring holder in a jeweler's vise while working on ring.

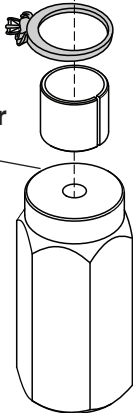

#004-847
Complete Assembly

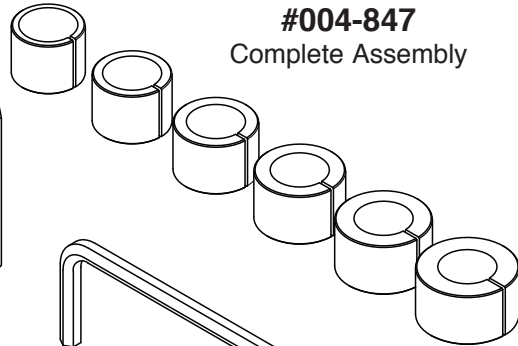

5/32" Hex Wrench
#002-429



900 Overlander Road • Emporia, KS 66801 USA
800-835-3519 • 620-343-1084 • Fax: 620-343-9640
grs@grstools.com • www.grstools.com
Last Updated: December 26, 2012